



X-Mount

rinstrum

SMART WEIGHING SOLUTIONS



For Tank and Hopper Applications

The X-Mount system is a legal-for-trade tank weighing system for commercial Legal For Trade applications. X-Mount systems are designed as retrofit weighing systems for fertilizer blenders or in industrial, pharmaceutical, or chemical applications. X-Mount systems are each customized to suit your exact size requirements to fit under existing or newly installed tank, hopper, or weigh vessels.

Send Rinstrum the hopper length, width and height of the load cell stands. We will custom fabricate a full stainless-steel bolt in replacement weighing system made to your exact dimensions.

- NTEP Certified – Certificate Number 17-114.
- High Accuracy Legal for Trade Weighting System.
- Capacities range from 1,000 lbs to 75000 lbs
- Technician friendly with easy installation features.
- Designed for demanding wash-down or corrosive environments.
- Hermetically sealed load cells rated to IP68 standards.



Key Features

- Load Introduction via a rocker pin assembly, which acts directly on the neutral zone of the load cell.
- Side, end and torsion load effects are eliminated.
- 100% uplift protection.
- Adjustable side-to-side checking.
- Exclusive threaded height adjustment for perfectly balanced loads.
- Constructed of 304 stainless steel.
- Customized height of X-mount to eliminate need for riser blocks.
- Customized length and width to fit specific tank and hopper leg requirements.

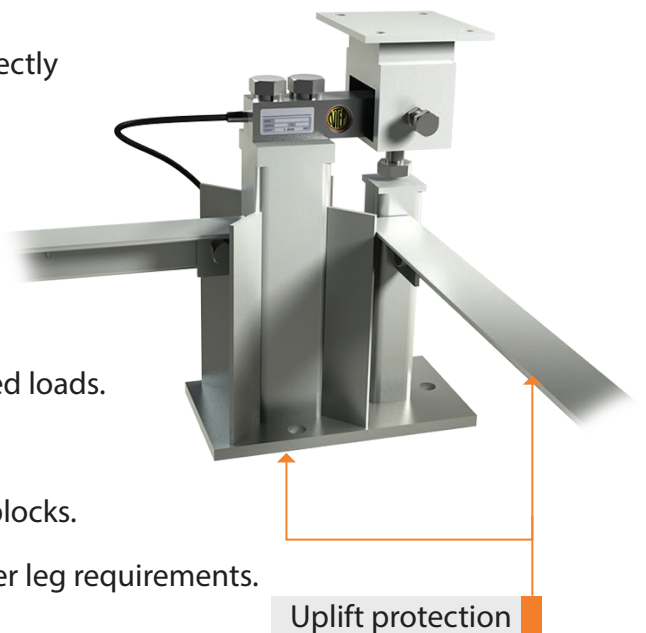

Model Numbering System

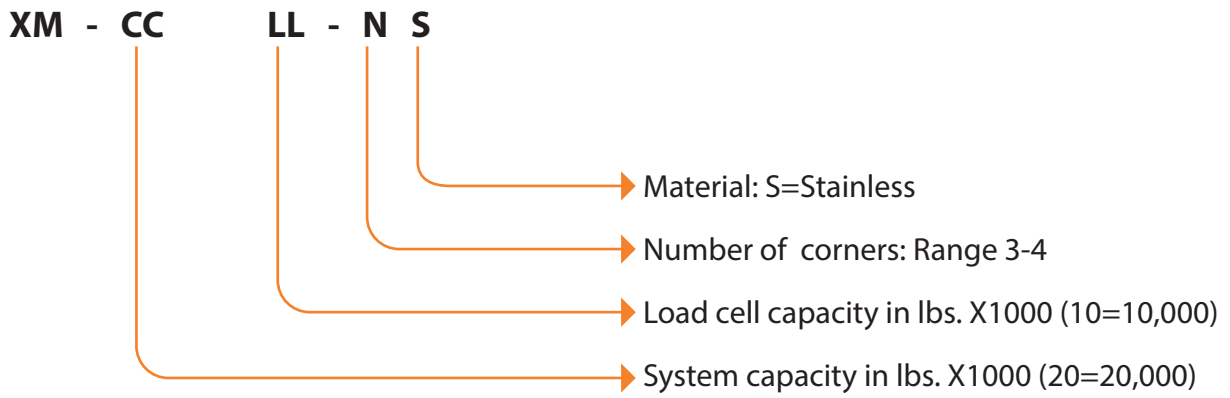

Common Model Configuration

Model	System Capacity	Load Cell Capacity	Number of Cells
XM-0201-4S	2000	1000	4
XM-0525-4S	5000	2500	4
XM-0804-4S	8000	4000	4
XM-1005-4S	10000	5000	4
XM-2010-4S	20000	10000	4
XM-3015-4S	30000	15000	4
XM-4020-4S	40000	20000	4
XM-7525-4S	75000	25000	4

- * 3 leg versions available on request.
- * NTEP is only approved up to 62,500 lbs.



XMNT-700-250

X-Mount

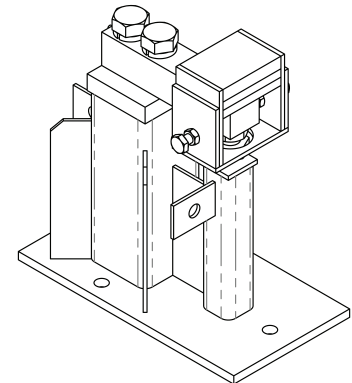
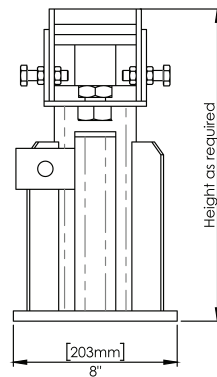
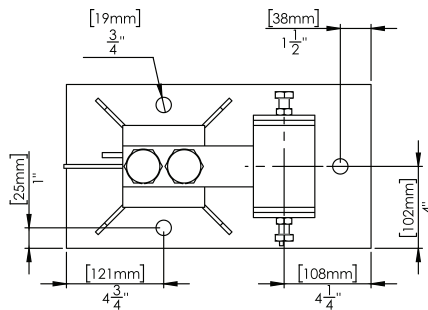
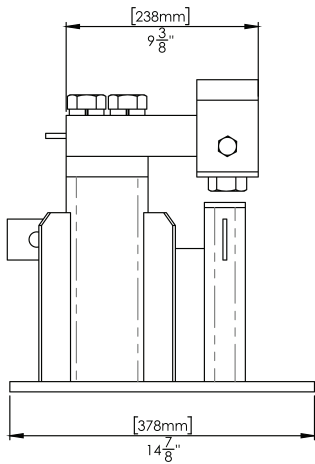
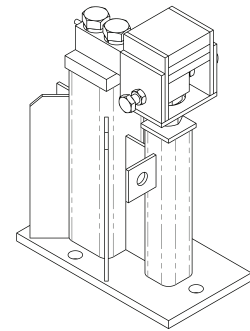
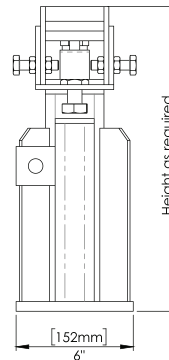
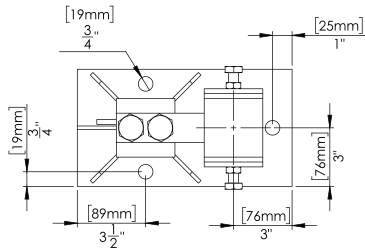
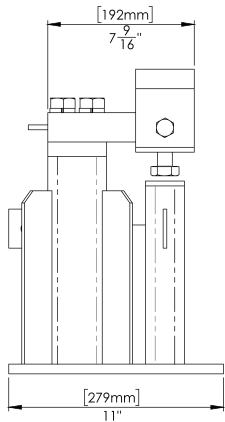
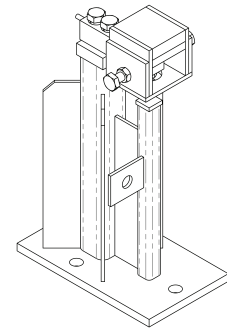
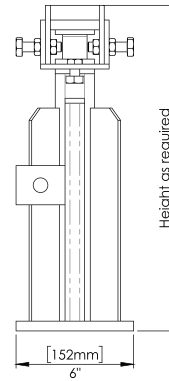
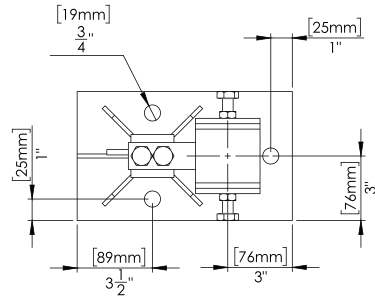
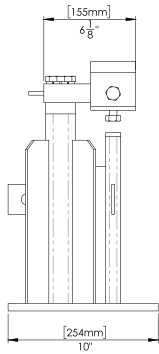

Southern IL Scale & Construction Inc
430 W South Ave Noble,
Illinois 62868

Phone: 1(800)441-1794
Email: sales@southernilscale.com

www.southernilscale.com



Contact Us